

WORCESTER HISTORICAL COMMISSION



CERTIFICATE OF APPROPRIATENESS & BUILDING DEMOLITION DELAY WAIVER APPLICATION

(For properties located in the Crown Hill, Massachusetts Avenue or Montvale Local Historic District)

Planning & Regulatory Services Division * 455 Main Street - Suite 404, Worcester, MA 01608 * Phone 508-799-1400, x51440
Office Hours are 8:30 am - 2:00 pm

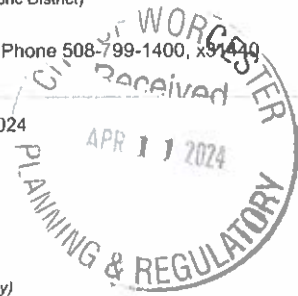

2024 APR 12 PM 1:35
City of Worcester City Clerk
Received

- 1. **Building Address/Location:** 54 west st Date: April 11, 2024
- 2. **Historic District:** Elm Park Neighborhood
- 3. **Date or Estimation of Original Construction:** 1910
- 4. **Description of Work:** *(please list and explain each proposed change separately. If replacing with like materials, note accordingly)*
 - Area of Work**
Siding and/or Trim
 - Describe "Other" Area of Work**
window and roof
 - Scope of Work - Describe Work to be Completed**
hardi plank siding pvc trim. windows and roof
 - Describe the Condition of Existing Materials to be Removed**
slate. wood siding and trim. wood window
 - Describe Proposed Materials**
cement board, pvc and wood window

- 5. **Owner of Property:**
 - DBA Name:
 - Owner Address: 18 Manor rd Millbury Massachusetts 01527
 - Owner Name: ying rizika
 - Owner Phone: 9787618887
- 6. **Contractor Information:**
 - Company Name:
 - Contractor Address:
 - Contractor Contact Name:
 - Contractor Phone:
- 7. **Type of Building Construction** wood
(Wood, Concrete, Steel, etc.)
- 8. **List all the Uses of the Building** business
(Residence, Business, Industrial, etc.) # of Stories: 3
- 9. **Code Violations/Health/Safety Issues:** 0
- 10. **Reasons for full or partial demolition (i.e. changes to the exterior) including other alternatives explored:**
fix leak and rotted
- 11. **Hardship, if applicable (usually is used when replacement is proposed in place of restoration of the original historic materials, features, or structures. Detailed cost estimates & comparisons of replacement v. restoration may be attached separately for the Commission's review)**
No

Owner's Signature certifying that the above information is true and accurate to the best of his/her knowledge:

 _____ Date: 4.10.24



54 West St Worcester Historical proposal

1 replace the siding.

Main building James Hardie plank Smooth finish exposures 5in, color aged pewter, evening blue or night gray. (pick which have in stock)

Back building James Hardie shingle siding Straight edge panel exposures 6.97", color aged pewter, evening blue or night gray. (pick which have in stock)

Please see the attached paper.

2. replace trim.

Replace window trim. Try to do it very close to the same trim.

Use pvc $\frac{3}{4}$ in x $3\frac{1}{2}$ in board as base. Put $2\frac{1}{4}$ in window trim on the top please the attachment for the trim.

New construction window will have $1\frac{1}{2}$ in edge so will make total window trim for 5in.

3. windowsill trim

Please the attachment

4. corner and base

Base use 8 in pvc board

Corner use 6 in pvc corner.

5. replace windows.

Back of the house: all the window without any grille

The main house: all the narrow windows without the grille.

Main house is two over two.

Andersen 400 series. Wood window.

Please see the attachment.

6. all the corbel and architectural decorations stay will fixed and painted.

7. Main house, the third-floor slate

Replace it with dark gray rectangle slate. Try to fix it. If can not fix it.



What can we help you find today?



Shrewsbury 10PM

01527

Ekena Millwork

2-1/4 in. x 5/8 in. x 84 in. Colonial Casing Moulding, PVC

★★★★★ [Questions & Answers](#)

Feedback

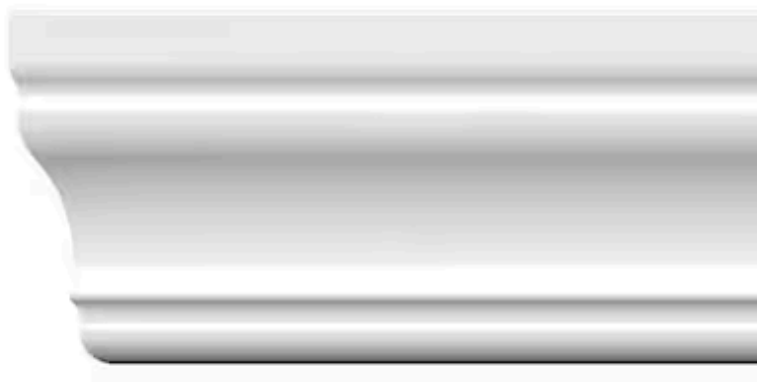
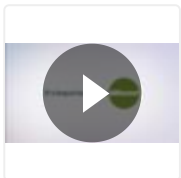
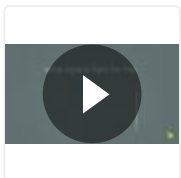

Menu

Quotes

Lists

Live Chat



Share Print

\$12²⁸

Pickup at [Shrewsbury](#)

Delivering to [01527](#)

Feedback

Ship to Store

May 15 - May 17

999 available

FREE

Delivery

Thursday, May 16

999 available

FREE

- 1 +

Add to Cart

Add to List

Add to Quote



Free & Easy Returns In Store or Online

Return this item within **90 days** of purchase. [Read Return Policy](#)

Product Details

Specifications

Quotes

Lists

Questions & Answers

Customer Reviews



Loading Recommendations



 Feedback

Loading Recommendations

Quotes

Lists



 Feedback



Quotes

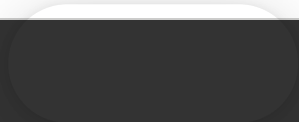

Lists



[Large greyed-out text area]

 Feedback

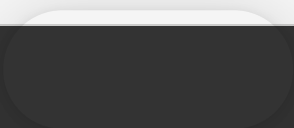
[Large greyed-out text area]



 Feedback

 Download Our App

How can we help?

Call 1-866-333-3551 | Text 78465

[Stores](#) | [©2000-2024 Home Depot](#) | [Privacy & Security Statement](#) | [Terms](#) | [My Preference Center](#) |

Quotes



Lists

Provide Feedback

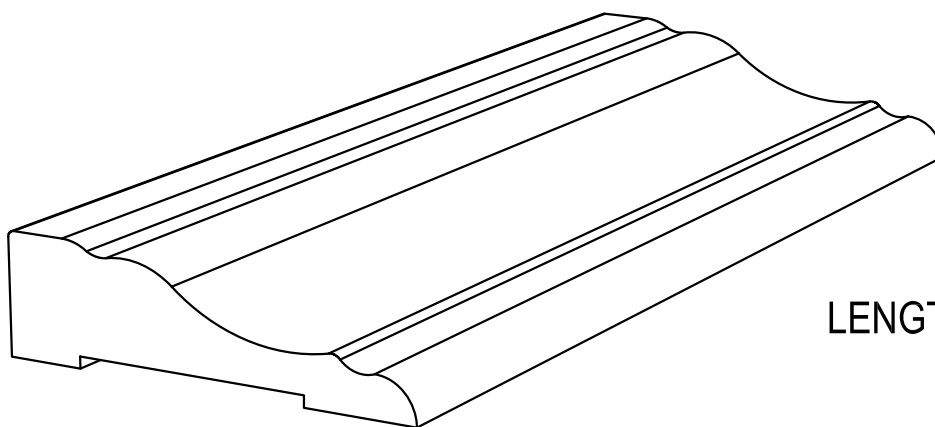
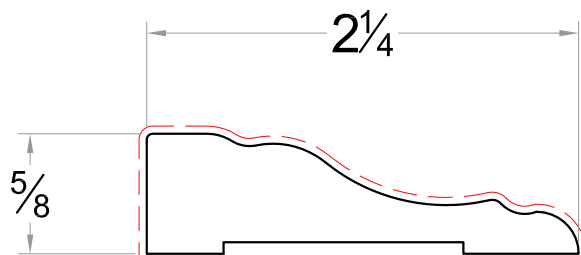

Quotes

Lists



LENGTH: 8'

NOTES:

1. INSTALLATION TO BE IN ACCORDANCE WITH MANUFACTURER'S SPECIFICATIONS.
2. DO NOT SCALE PRINTED DRAWING.
3. THIS DRAWING IS INTENDED FOR USE BY ARCHITECTS, ENGINEERS, CONTRACTORS, CONSULTANTS AND DESIGN PROFESSIONALS FOR PLANNING PURPOSES ONLY.
4. CONTRACTOR'S NOTE: FOR PRODUCT AND COMPANY INFORMATION VISIT www.royalbuildingproducts.com

5445

SCALE 1:1

Colonial Casing

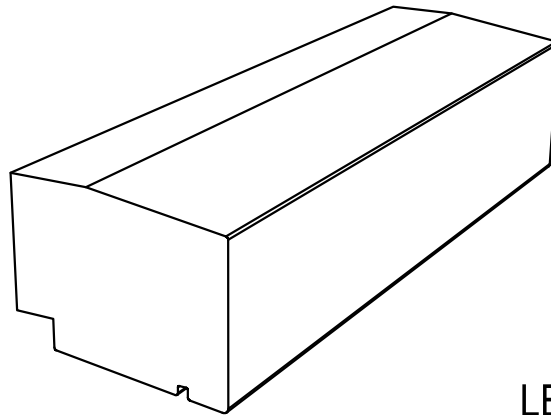
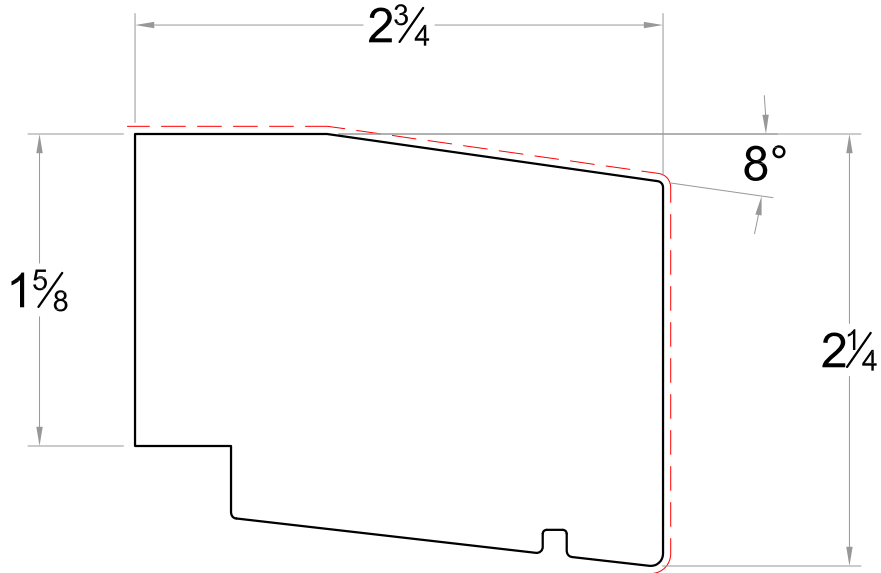

LENGTH: 16'

NOTES:

1. INSTALLATION TO BE IN ACCORDANCE WITH MANUFACTURER'S SPECIFICATIONS.
2. DO NOT SCALE PRINTED DRAWING.
3. THIS DRAWING IS INTENDED FOR USE BY ARCHITECTS, ENGINEERS, CONTRACTORS, CONSULTANTS AND DESIGN PROFESSIONALS FOR PLANNING PURPOSES ONLY.
4. CONTRACTOR'S NOTE: FOR PRODUCT AND COMPANY INFORMATION VISIT www.royalbuildingproducts.com

7640

SCALE 1:1

Sill Nose



Magnolia Home | James Hardie Collection

Tell the story of your home with beautiful colors, styles and textures you love- all curated by Joanna Gaines. This collection was inspired by earthy and neutral tones and created to help simplify the process of re-siding your home, so you can design with confidence. All products come with ColorPlus® Technology finishes for added beauty with lower maintenance.

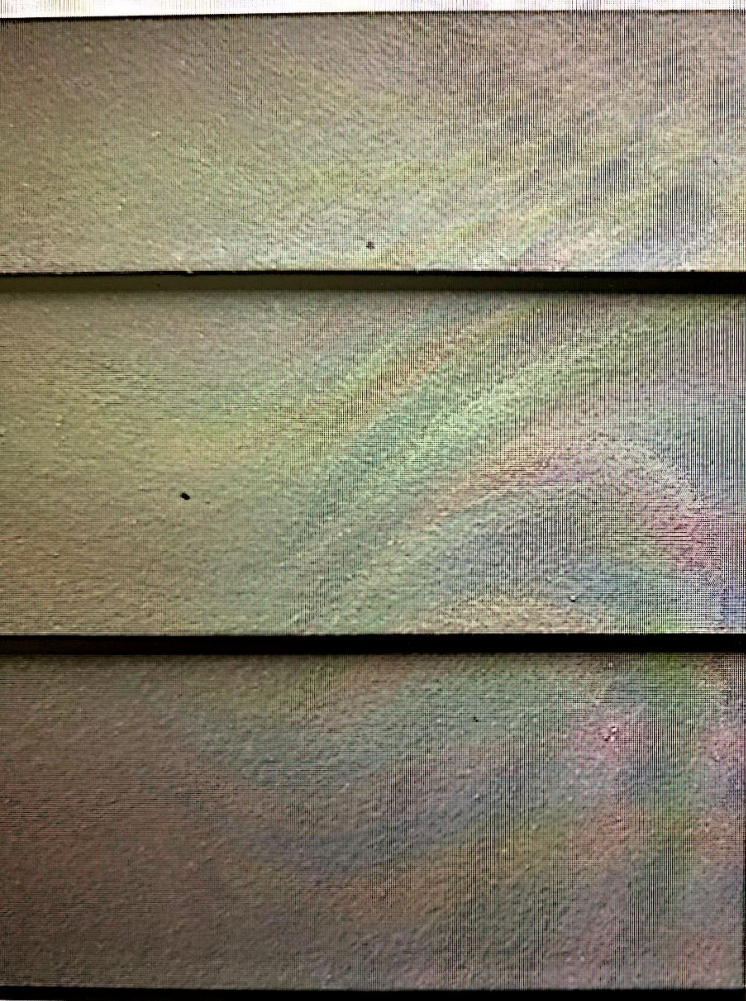

SIDING COLORS

It's About Thyme

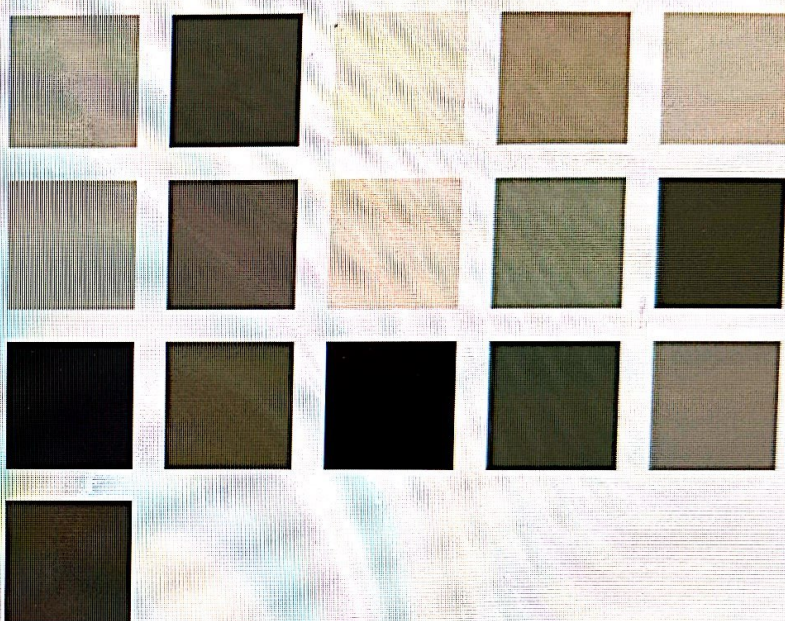

[Request a Quote >](#)

[Request a Sample >](#)

Colors shown may vary due to screen resolution. Please see actual product sample for true color.

AVAILABLE SIZES

THICKNESS: 0.312"	WIDTHS:	8.25"	7.25"	6.25"	5.25"
LENGTH: 144" boards	EXPOSURES:	7"	6"	5"	4"

Classic shades—engineered with long-lasting ColorPlus® Technology—will make a statement that resonates for generations. The tried and true colors of James Hardie's Statement Collection™ products were designed for every home. They're our most popular hues. And they are readily available in your region.

SIDING COLORS

Aged Pewter

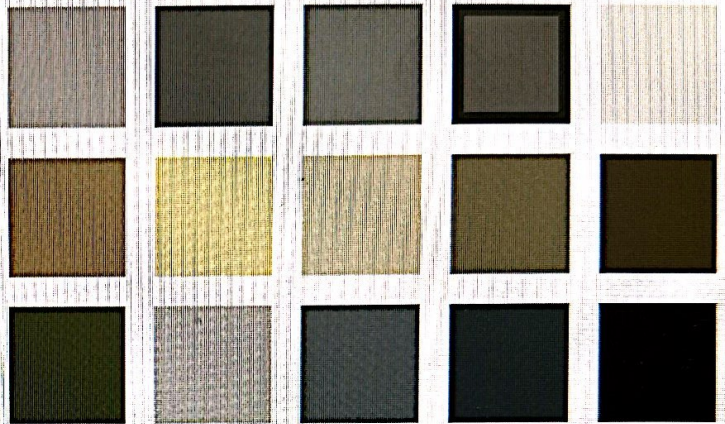

[Request a Quote >](#)

[Request a Sample >](#)

Colors shown may vary due to screen resolution. Please see actual product sample for true color.

AVAILABLE SIZES

THICKNESS: 0.25"

WIDTHS: 15.25"

LENGTH: 48" boards

EXPOSURES: 6.976"

[Warranty Information >](#)